

RXT-6802/RXT-6802 Lite



Advanced 800G Multi-service Test Module

800GE IEEE & ETC
800G PCS/FEC Testing
2x400GE Testing
4x200GE Testing
8x100GE Testing
400GE to 1GE Testing
2x200GE Testing

True All-in-one up to 800GE
Dual test ports for all interfaces
Best-in-class intelligent cooling system

NEW

for RXT-1202 Modular Test Platform



Advanced 2x 800G/400G Multi-service handheld test set for Lab to Field Applications

VeEX® RXT is the industry's most flexible, compact, and future-proof handheld test solution for Core, Metro, Datacenter, and Access applications. The RXT-6802 and RXT-6802 Lite offers the flexibility of testing current interfaces and supporting future expandability for applications including Transport, Aggregation, cross-connect, 5G x-haul, and NEMs field support.





Module Highlights

- 2x QSFP-DD800G test ports
- Supports pluggable client and line side DCO transceivers including QSFP-DD800, QSFP112, QSFP-DD, QSFP56 and QSFP28
- 800G to 100G Ethernet applications
- FEC and BER signal integrity testing
- PAM4 and NRZ SerDes up to 112G
- Independent port operation
- Comprehensive I2C capabilities for transceiver qualification
- Coherent ZR/ZR+ support
- PCS/FEC, Lane BERT, Throughput, RFC2544, Y.1564 V-SAM tests
- Compact handheld capable of generating up to 1.6 Tb/s of test traffic
- Field-proven performance and reliability
- Outstanding signal integrity
- Advanced cooling
- Forward-looking module design keeps evolving with fast-paced technology
- All-in-one hardware configuration, ready to meet leading-edge as well as legacy applications

Applications

- Transceiver, AOC, AEC, and DAC validation
- Signal integrity testing
- Network equipment, systems, and IC development
- Network verification and service delivery
- R&D, system verification test, FAEs, carrier labs, and Field
- Production and manufacturing test
- Data center cross-connect and Interconnect
- Long-haul link performance validation and troubleshooting
- ZR/ZR+ wavelength tuning, transceiver configuration and verification

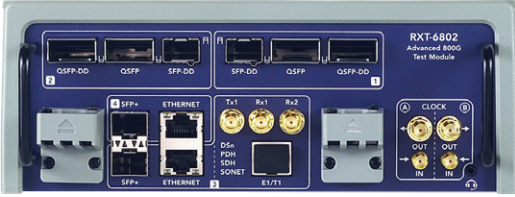
Test Interfaces

| CONFIGURATIONS | | |
|---|---|--|
| |  |  |
| Supported Test Interface (Ports) | RXT-6802 | RXT-6802 Lite |
| 2x QSFP-DD | ● | ● |
| 2x QSFP56/QSFP28/QSFP+ | ● | ● |
| 2x SFP-DD/SFP56/SFP28 | ● | ● |
| 2x SFP+/SFP | ● | ● |
| 2x RJ45 | ● | -- |
| 1x RJ48 and 3x SMA | ● | -- |
| 2x Clock Inputs and 2x Outputs | ● | ● |
| Independent Test Port Groups ¹ | 4 | 2 |
| Test Applications | | |
| 400GE | ● | ● |
| 200GE | ● | ● |
| 100GE | ● | ● |
| 50GE | ● | ● |
| 40GE | ● | ● |
| 25GE | ● | ● |
| 10GE | ○ ² | ○ ² |
| 1000Base-X | ○ ² | ○ ² |
| 100Base-X | ○ ² | -- |
| 10/100/1000BASE-T | ○ ² | -- |
| 1G to 16G Fibre Channel | ○ ² | -- |
| OTU4/OTU3 | ○ ² | ○ ² |
| OTU2/OTU1 | ○ ² | ○ ² |
| OTU2e/OTU1e | ○ ² | ○ ² |
| SDH/SONET (optical) | ○ ² | -- |
| SDH/SONET/PDH/DSn (electrical) | ○ ² | -- |

1. Also refers to the number of concurrent and independent tests supported

2. Planned

| Interface | Standard | Total Simultaneous Tests per Module |
|--|---|-------------------------------------|
| 800GE KP4 RS-FEC | IEEE & ETC 800GAUI-8 PAM4 (106G per lane) | 2x |
| 2x 400GE KP4 RS-FEC ³ | 2x 400GAUI-4 PAM4 (106G per lane) | 2x |
| 8x 100GE KP4 RS-FEC ³ | 8x 100GAUI-1 PAM4 (106G per lane) | 2x |
| 4x 200GE KP4 RS-FEC | 4x 200GAUI-2 (106G per lane) | 2x |
| 400GE KP4 RS-FEC | 400GAUI-8 PAM4 (53G per lane) | 2x |
| 4x 100GE KP4 RS-FEC ³ | 4x 100GAUI-2 PAM4 (53G per lane) | 2x |
| 2x 200GE KP4 RS-FEC | 2x 200GAUI-2 (106G per lane), 2x 200GAUI-4 (53G per lane) | 2x |
| 100GE KR4 RS-FEC | CAUI-4 NRZ | 2x |
| 100GE | CAUI-4 NRZ | 2x |
| L1 Unframed Lane BERT, PRBSQ and SSPRQ Test Patterns | 106.25G PAM4 and 53.125 PAM4 and 26.5625G NRZ | 2x |

3. Planned in future software release

Note: For OSFP support, refer to the RXT-6811 datasheet

QSFP-DD800 Port Specifications

- Supports pluggable QSFP-DD800, QSFP112, QSFP-DD, QSFP56 and QSFP28 modules, AOCs, AECs, and DACs
- Supports DCO, ZR and ZR+
- Up to 800 Gbps data rate
- SerDes Lane rates
 - 8x 106G PAM4 SerDes
 - 8x 53G PAM4 SerDes
 - 8x 26G NRZ SerDes
- QSFP-DD MSA Hardware Specification Rev 7.0
- OIF CMIS 5.2
- OIF 400ZR 2.0
- Supports transceivers up to 30 watts

Host Test Module Features

Signal Integrity Settings

- Adjustable TX swing, pre-cursor, pre-cursor 2, and post-cursor
- Receiver auto-tune mode for best performance

Transmit Clock Source

- Chassis Clock Sources, (reference platform datasheet):
 - Internal stratum 3, 1.544 MHz, 2.048 MHz, 10 MHz, BITS/1.544 Mbps, or SETS/2.048 Mbps
- Recovered: from the incoming signal
- External: 1.544 MHz, 2.048 MHz, or 10 MHz; SMA connector (input shared between ports)

Line Frequency Offset Generation

- Line frequency offset generation ± 150 ppm in 0.1 ppm steps, affects all lanes
- Constant generation
- Ramp generation: min offset, max offset, step size, and step duration settings
- Instantaneous offset

Line Frequency Measurement

- Displays measured transmit line frequency offset from external reference clock in both Hz and ppm
- User defined alarm threshold for external transmit reference clock offset measurements
- Provides line frequency measurements in Hz with offset in Hz and ppm
- User defined alarm threshold for received line frequency measurements

Module Configuration & Port Groups

- Provides 2x port groups per test module
- Each port group can be reserved by an independent user and operated independently
- Factory Hardware Module options include:
 - Module with dual port groups
 - Module with reduced port option and single port group only

Multi-Lane Unframed BERT

Per Lane Unframed BERT Test Pattern Generation and Measurement

Rates

- PAM4: N x 106.25G, N x 53.125G
- NRZ: N x 26.5625G

Patterns

- PAM4 patterns: SSPRQ, PRBS9Q, PRBS11Q, PRBS13Q, PRBS15Q, PRBS20Q, PRBS23Q, PRBS31Q; normal and inverted
- 25G NRZ patterns: PRBS9, PRBS11, PRBS13, PRBS15, PRBS20, PRBS23, PRBS31; normal and inverted

Results

- Per lane loss of pattern sync, bit error count, average, and current error rate results

Error Insertion

- Bit error generation per lane; supports single and rate insertion

Transceiver Test Applications*

Information Display

- Displays commonly used transceiver information saved in the I2C registers such as vendor name, part number, serial number, HW/FW revisions, power class, etc.

QSFP-DD Application Advertising

- Provides the modules, programmed capabilities
- Programs the modules internal settings

Laser (ITLA) Tuning

- Grid spacing, channel number, frequency, wavelength
- Fine tuning offset
- Displays modules, internally reported frequency and wavelength measurements
- Displays modules, programmed capabilities

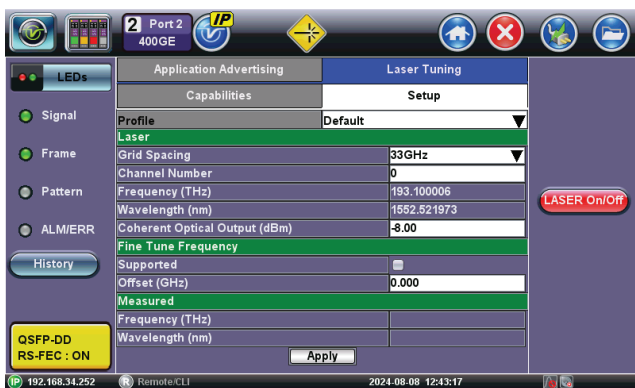

ZR Tuning Menu

Coherent Optical Power

- Coherent optical power adjustment and measurement

Optical Power

- Global and per optical lane power output enable/disable
- TX and RX per lane and broadband optical power level monitoring
- Current, min and max measurements
- Verifies transceiver internal or user defined thresholds for high alarm, high warning, low alarm, and low warning alarms



TX Power Level Settings



New TX Power Level in the Signal tab

TX Bias Current

- Current, min and max measurements
- Verifies transceiver internal or user defined thresholds for high alarm, high warning, low alarm, and low warning alarms

Coherent QSFP-DD C-CMIS Media and Host Performance Monitoring Stats (PM)

- Media Lane PM: Frames with Uncorrectable Errors, Corrected Bits, Frames, and Bits
- Data Path Host Interface PM: Frames with Uncorrectable Errors, Corrected Bits, Frames, and Bits
- Chromatic Dispersion
- Differential Group Delay
- Second Order Polarization Mode Dispersion
- State of Polarization Rate of Change
- Polarization Dependent Loss
- Carrier Frequency Offset
- OSNR
- eSNR
- Error Vector Magnitude
- TX Optical Power
- RX Optical Power
- RX Optical Signal Power
- Modulation Error Ratio

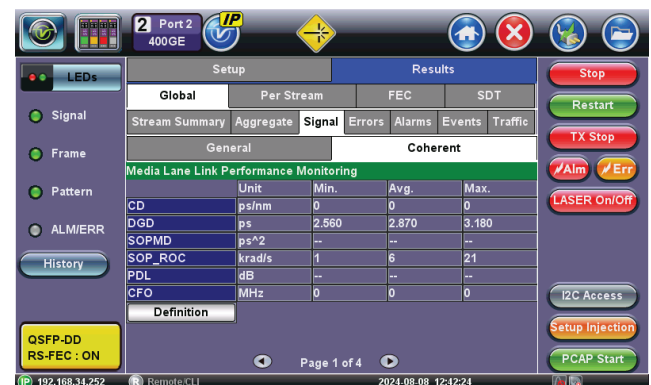

Coherent ZR+ Internal Media Lane Monitoring Statistics

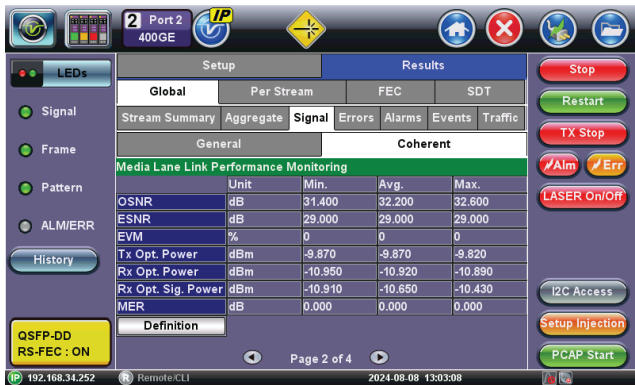

Coherent ZR+ Internal Media Lane Monitoring Statistics

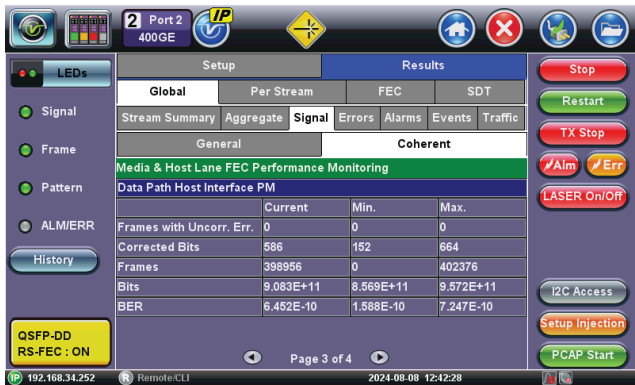

Data Path Host Interface FEC Performance Monitoring



Media Lane FEC Internal Performance Monitoring

Temperature Monitoring

- Internal and cage temp monitoring
- Current, min and max measurements
- Verifies transceiver internal or user defined thresholds for high alarm, high warning, low alarm, and low warning alarms

Variable 3.3V ±5% Transceiver Power

- Each port supports a variable 3.3V transceiver power supply to qualify transceiver specifications
- Provides host estimated current, min, and max transceiver power, voltage, and current measurements
- Displays the transceiver internal current, min, and max voltage measurements
- Verifies transceiver internal or user defined thresholds for high alarm, high warning, low alarm, and low warning alarms

I2C

- Complete I2C register read/write access

*Note: Features are dependent on the installed pluggable transceiver.

Advanced Optical Transceiver Test Suite

- Pre-FEC BER validation on a per-lane basis, over operational voltage and frequency offset range to verify optical module integrity before FEC is applied to the PAM4 signal.
- Pre-Framed BER (Lane BERT) validation for non PAM4 interfaces.
- Voltage, temperature, and Pre-FEC BER are monitored and displayed for the duration of the test. A histogram function clearly displays all three measurements for easy correlation and tracking of any abnormal changes.
- Pre-FEC BER and Optical Power threshold settings for PASS/FAIL indication.
- Pre-emphasis: Pre-taps, post-taps, and attenuation settings for PAM4 signal conditioning on the host side to help verify and stress transceiver tolerance and performance.
- Supply Voltage Tolerance Verification: Sweep range from 3.135V to 3.465V (3.300V +/- 5%) to verify compliance with optical transceiver MSA standard.
- Power Consumption Verification: Monitors the optical transceiver's power consumption (Watts), to verify conformance to its specified power class.
- Temperature Monitoring: QSFP-DD module and cage temperature monitoring with built-in shutdown protection of the optical module if the temperature increases beyond a certain high temperature.
- Frequency Tolerance Verification: Sweep range from -100 ppm to +100ppm (in 0.1ppm/step).
- I2C Baud Rate Sweep: QSFP-DD and OSFP sweep range 100K to 4000K. QSFP28 sweep range (20K to 1000K).

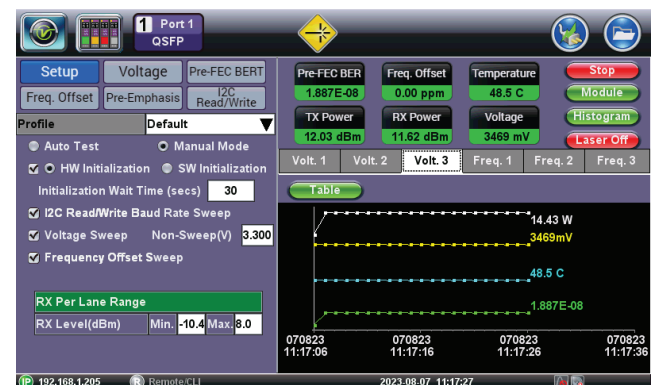

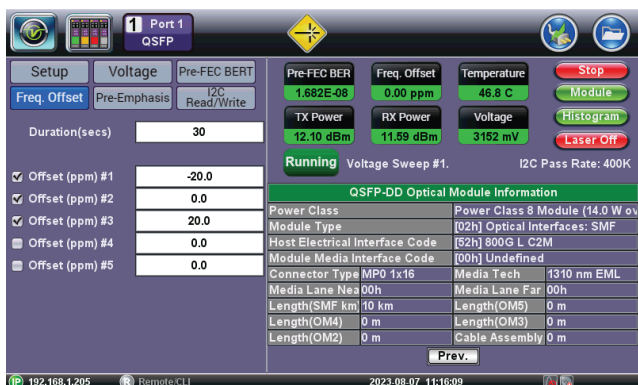

PCS/FEC Layer

PCS/FEC Lane Numbering

- Supports lane number swapping and rotation
- Displays received lane ID, lane # and channel assignments

PCS/FEC Lane Skew

- Per lane static skew generation and measurement

Error Generation

- FEC Correctable Symbol
- FEC Uncorrectable
- 256B/257B Transcode
- 64B/66B
- SYNC HDR, BIP8 (CAUI-4)
- Single and rate insertion

Alarm Generation

- FEC LOA
- High SER
- FEC REM Degraded SER
- FEC Local SER Degraded
- FEC Alignment marker loss per lane (LOAMPS)
- HighBer, Block Lock, (CAUI-4)

Error Results

- FEC Correctable Symbol with symbol error per codeword distribution
- FEC Uncorrectable
- 256B/257B Transcode
- 64B/66B
- SYNC HDR, Alignment Marker, BIP8 (CAUI-4)

Alarm Results

- FEC LOA
- FEC High SER
- FEC Degraded SER
- FEC Remote Degraded SER
- FEC Local Degraded SER
- FEC Alignment marker loss per lane (LOAMPS)
- HighBer, Block Lock, (CAUI-4)

Ethernet/IP

Traffic Generation/Test Stream Flows

- Multiple independent test stream flows with separate rate, addressing and traffic parameters
- The test stream is generated with a signature field in the beginning of the payload area for traceability and measurement purposes
- 800/400GE (16 streams) and 100 (32 streams)
- L2, L3 or L4(UDP)
- IP Version: IPv4 or IPv6
- Frame sizes: 64 to 16,000 bytes; fixed, random, increment, or decrement generation
- Test Pattern: PRBS31 normal and inverted, 32-bit user
- VLAN tags up to 4 levels
- MPLS tags up to 4 levels
- Custom frame tags

Traffic Rate Generation

- Full rate generation and analysis
- Constant, IPG, Ramp or Burst scheduling

Flow Control

- Pause frame generation and response

Error Generation

- Port based - Runt, FCS, IP Checksum, and UDP Checksum
- Per test stream - Payload Bit and Sequence
- Single and rate insertion

Alarm Generation

- Remote and Local Fault alarms
- Auto reply to Local Fault option

Benchmarking

- Throughput
- RFC 2544
- Y.1564 VSAM

Service Disruption Time (SDT) Measurement

- Min, max, and average measurement

RFC2544 Compliance Testing

- Automated tests compliant with RFC2544 with configurable threshold values and maximum transmit bandwidth settings
- Throughput, Latency, Jitter, Frame Loss, and Back-to-Back (burst) tests
- Frame sizes: 64, 128, 256, 512, 1024, 1280, and 1518 bytes including 2 user configurable frames

Loopback Mode

- Layer 2: all incoming traffic is looped back with MAC source and destination addresses swapped
- Layer 3: all incoming traffic is looped back with MAC and IP source and destination addresses swapped
- Layer 4: all incoming unicast traffic is looped back with the MAC, IP, and UDP/TCP ports swapped.

Loopback traffic filters with all MAC/VLAN/IP parameters configurable

All key measurements on received traffic provided on the loopback port

Result Filtering

- Results can be filtered by up to 4 VLAN tag TPIDs

Transmit and Receive Port Counts

- Packets, packets/second, bytes, Mbps, % BW
- VLAN packets, MPLS packets
- IPv4 and IPv6 packets
- L1 and L2 Statistics

Receive Port Counts

- TCP, UDP, IGMP, ICMP packets
- Broadcast, multicast, unicast
- Jumbo, super jumbo packets (greater than 9216 bytes)

Port Distribution Results

- VLAN distribution by tag level and quality of service level
- MPLS distribution by tag level and traffic class
- Frame size distribution for 64, 65-127, 128-255, 256-511, 512-1023, 1024-1518, 1519–max byte ranges with support for counts and percentage

Port Utilization Counts

- Total, IPv4, IPv6, VLAN, MPLS binning
- Current, min, max, and average % BW, Mbps, and packets per second statistics for generated and received traffic
- L1 and L2 statistics

Port Errors

- Runt, FCS, IP Checksum, UDP Checksum, and undersized
- Displays counts, errored seconds, current and average error rates

Port Alarms

- Loss of Link, Local Fault, and Remote Fault

Test Stream Results

- Independent set of results per test stream
- Transmitted and received frame counts, byte counts and rate
- Sequence errors, payload bit errors and lost frame counts in errored seconds, current and average rates
- Latency min, max, and average measurements
- Packet/frame jitter min, max, and average measurements
- L1 and L2 statistics

Packet Capture and Decode

Configurable capture filters

- MAC and IP
- UDP and/or TCP
- Multicast, Broadcast, IP Checksum error, UDP/TCP Checksum Error events

Integrated Wireshark™ packet decode

Packet captures can be saved and exported PCAP capture format, compatible with Wireshark

Multiple Streams Throughput Testing

Up to 16 (400G/800G), 32 (100G) independent traffic streams generation and analysis, with configurable filters on 40GE and 100GE interfaces

Up to 10 independent traffic streams generation and analysis, with configurable filters on 10GE interface

Up to 8 independent traffic streams generation and analysis, with configurable filters on 1GE interface

Each stream can be set with independent frame size, bandwidth, traffic profile, and QoS levels

MAC flooding feature: generates test frames with up to 4096 incrementing Source and/or Destination MAC addresses

Test Patterns: PRBS: 231-1, 223-1, 215-1, 211-1, normal and inverted patterns, All 0s, All 1s and User Defined

Error Measurements: Bit/BER (Single Stream only), FCS/CRC, Jabber/Runt frames, IP Checksum, TCP/UDP Checksum, Frame Loss (count and %), Out of Sequence

Alarm Detection

- 10GE: LOS, LOSync, Service disruption (current, total, last, min/max, # of occurrences), Local Fault, Remote Fault, PCS-HI-BER, PCS-LOBL, WAN SONET Alarms: LOF, AIS-L and RDI-L WAN SDH Alarms: LOF, MS-AIS, MS-RDI
- 1GE: LOS, LOSync, Service disruption (current, total, last, min/max, # of occurrences)

Frame/Packet Statistics

- Multicast, broadcast, unicast, pause frames, frame size distribution

Rates (min, max, average and current): frame rate, bandwidth utilization, frame rate, line rate, data rate

- Frame arrival time (min, max, average and current), Frame Delay Variation
- Round Trip delay or One-Way Delay OWD* (min, max, average and current) and Histogram distribution with configurable sampling period and threshold

RFC2544 Compliance Testing

Automated tests compliant with RFC2544 with configurable threshold values and maximum transmit bandwidth settings Throughput, Latency, Jitter, Frame Loss, and Back-to-Back (burst) tests

Frame sizes: 64, 128, 256, 512, 1024, 1280, and 1518 bytes including 2 user configurable frames

Loopback Mode

Layer 2: all incoming traffic is looped back with MAC source and destination addresses swapped

Layer 3: all incoming traffic is looped back with MAC and IP source and destination addresses swapped

Layer 4: all incoming unicast traffic is looped back with the MAC, IP, and UDP/TCP ports swapped.

Loopback traffic filters with all MAC/VLAN/IP parameters configurable

All key measurements on received traffic provided on the loopback port

ITU-T Y.1564 V-SAM Test

V-SAM test suite compliant with ITU-T Y.1564 standard

Support for Multi-stream traffic generation, Service Configuration and Service Performance tests

Independently configurable for each stream

- Frame size: Fixed or EMIX pattern (1GE only)
- Bandwidth profile parameters: CIR, EIR, CBS (1GE only), EBS (1GE only) Traffic Policing
- Service acceptance criteria: FLR, FTD, IFDV, AVAIL

Simple summary Pass/Fail results tables and drill down capability with detailed measurements (Frame Loss, Frame Transfer Delay, Frame Delay Variation, Availability) for each service

Platform Highlights

The RXT family of advanced test modules offer a full range of link and service testing capabilities, from Core to Access, from Lab to Field and from 64k to 400G, with a complete range of communication technologies, including OTN, SDH/SONET, PDH/Dn, Carrier Ethernet, SyncE, 1588v2 PTP, Fibre Channel, OTDR, OSA. All supported by a single rugged forward-looking hand-held test platform.

- Smallest, lightest, most complete, and truly portable hand-held 400G test solution.
- Built-in VeExpress™ client for cloud-based asset management, software updates and licenses. Buy, rent or share licenses.
- Built-in VeSion® R-Server™ client for test results upload, workflow integration, and asset management.
- Complementary full-featured C/DWDM OSA and tunable OTDR modules available in the RXT family.
- Flexible remote access and remote control via EZ Remote™, web browser, VNC®, ReVeal RXTS PC software, and SCPI commands.
- Fast test results transfer via USB memory stick and web client.
- LAN, WiFi and Bluetooth® management interface options.
- Intuitive graphical user interface for straightforward operation.
- Fast boot-up and ready-to-test times.
- The RXT-1202 high-power platform can run up to four simultaneous tests, including 2x 400G and high-power class transceivers.
- High-capacity field-exchangeable Li-ion battery pack offers over 30 minutes of continuous operation at 400GE (single LR4). FAA, TSA, US DoT, IATA, UN38.3 (49 CFR 175.10) compliant for safe carry-on transportation in passenger aircraft cabins.
- Optional built-in high-precision multi-band GNSS Receiver and/or Atomic Clock references for frequency and timing applications.
- Color LCD with touch screen.

General

| | |
|------------------------|---|
| Power Consumption | |
| Maximum | 300 Watts ³ |
| Environmental | |
| Operating Temperature | 5°C to 35°C (41°F to 95°F) |
| Storage Temperature | -20 to 70°C (-4 to 158°F) |
| Humidity | 5% to 90% non-condensing |
| Dimensions (W x H x D) | |
| RXT-6802 Module | 214 x 178 x 76 mm (8.4 x 7.0 x 3.0 in) |
| RXT-1202 Chassis | 267 x 180 x 66 mm (10.8 x 7.1 x 2.6 in) |
| Test Set (combined) | 267 x 208 x 110 mm (10.8 x 8.2 x 4.3 in) |
| Weight | |
| RXT-6802 | 1.65 kg (3.64 lb) |
| RXT-1202 | 1.30 kg (2.87 lb) |
| 9-cell Li-ion battery | 0.55 kg (1.21 lb) ⁵ |
| Test Set (Total) | 3.50 kg (7.72 lb) |

1. Basic web and cloud services available free of charge
2. Check with factory for specific module versions compatible with the RXT-1202 platform
3. Requires RXT-1202 high-power platform and A01-00-019G 24VDC/12.5A AC/DC adapter.
4. Range specified up to 100G operation. For 400GE and 800GE it is recommended to be operated below 32°C (90°F).
5. Requires B02-09-007G high-capacity battery pack. Battery operation may not be available for high power application above 100G. For safety reasons, if the battery's current limit is exceeded, the test module will automatically shut down.

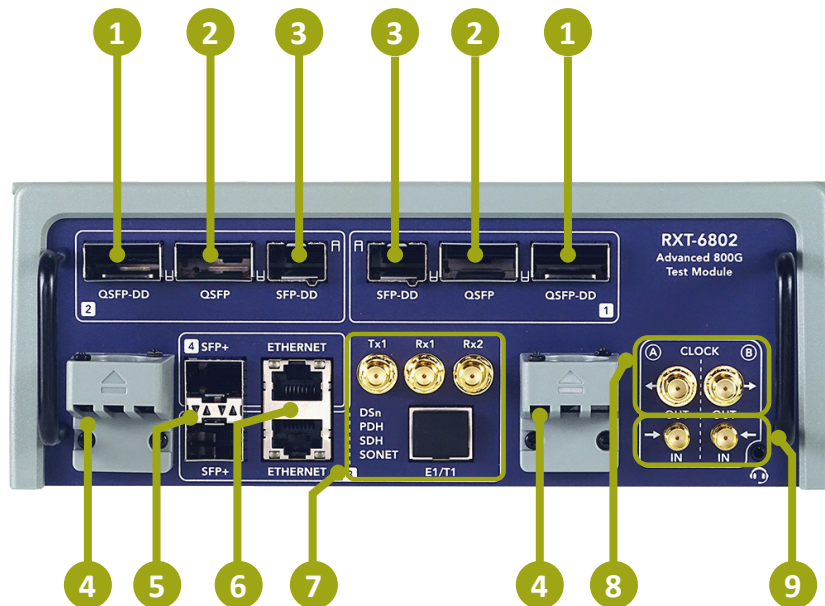

- | | |
|--|--|
| <ul style="list-style-type: none"> 1 QSFP-DD800 (800GBASE-X), QSFP-DD (400GBASE-X, 400GZR/ZR+), QSFP56/QSFP28 (200G, 100G, 50G) 2 QSFP+ (40G) 3 SFP-DD56/SFP56/SFP28 (100G, 50G, 25G BASE-X) 4 External QSFP-DD Cooling Fans. Cools exposed transceivers head (Field replaceable). 5 2x SFP+/SFP (10G, 1G BASE-X). Future use. | <ul style="list-style-type: none"> 6 2x RJ-45 (10/100/1000BASE-T) 7 Coaxial SMA and RJ48 (future use) 8 2x Independent Reference Clock Outputs (future use) 9 2x Independent Reference Clock Inputs (future use) |
|--|--|