

www.fiberpro.com

Auto Alignment System

IFA-600



- Photonic Integrated Circuit (SiP devices)
- Integrated Optical Circuit (LiNbO3 chip)
- VOA (Variable Optical Attenuator)
- AWG (Arrayed Waveguide Gratings)
- PLC Splitter
- Collimator
- Other optical devices



FIBERPRO

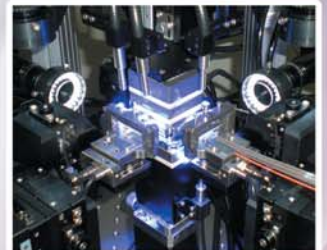
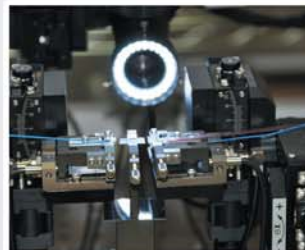
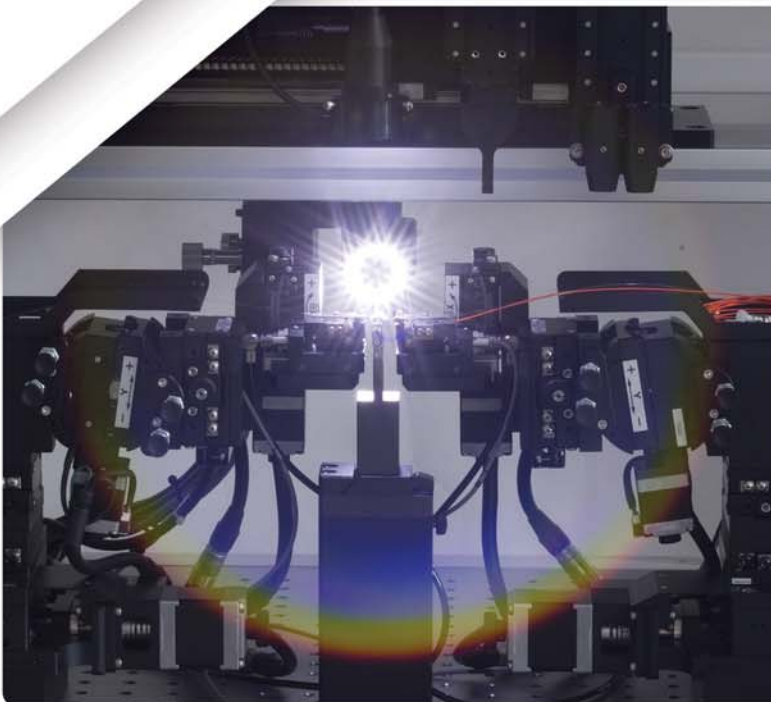

Auto Alignment system IFA-600 Series

Instrument



Multipurpose Driving Unit
MDU1000

Supporting optical source and/or current source



Multichannel Optical Power Meter
(Current Meter) : PM2000

Wavelength range : 1270nm ~ 1630nm
Power dynamic range : +5dBm ~ -80dBm
Resolution : 0.01dB
Free space connector type
Interface : TCP/IP, RS232, GPIB



Features

- Automatic alignment with excellent repeatability based on optimized alignment algorithm and precision stage control
- Automatic gap control and angle alignment using precision displacement sensor
- Quick input port alignment with multimode fiber
- Fast initial alignment based on vision processing and 2D scanning algorithm
- Convenient graphic user interface and versatile function for data management
- Remote controllable via user software
- Compact mechanical design

Principal Mechanical for Alignment

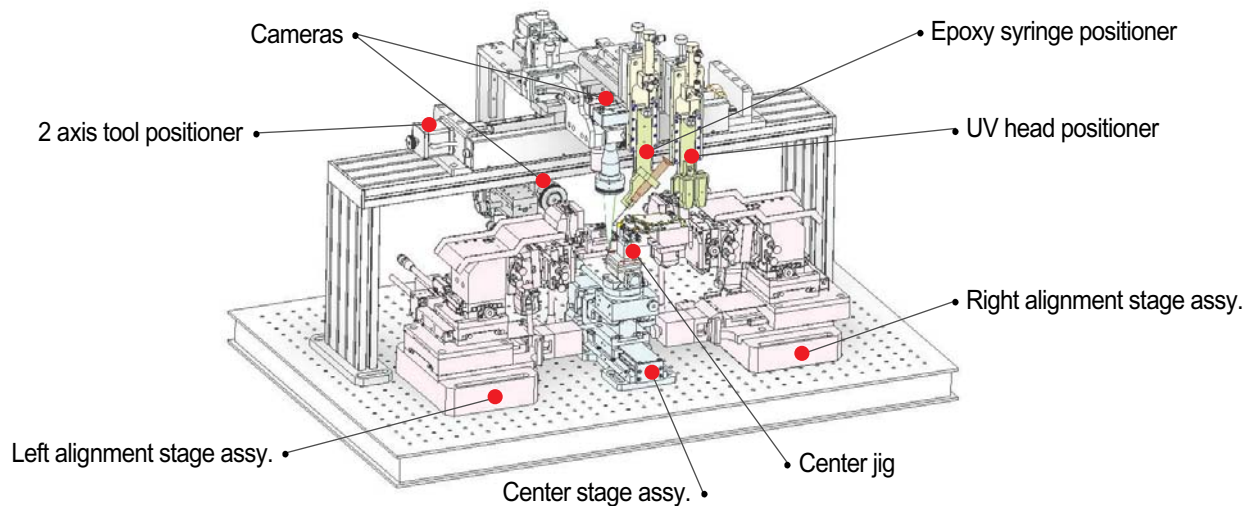

Alignment stage assy. (Left/Right stage)

- Supporting various chip angles
 0° , $\pm 8^\circ$, $\pm 5^\circ$
Quick adjustment of angle bracket (customizable)
- Detachable FAB jig (customizable)
- Sensor for automatic gap control
- Various types of jig/parts
(e.g. gripper, electrical probes) supported

Center stage assy.

- Highly customizable center jig (detachable)
- Optional temperature control

Tool positioner assy.

- Position control of cameras, UV LED head

Option

UV curing system

- Automatic start/stop control by system software
- Automatic positioning of UV guide/head in up/down direction for UV curing process
- Installed on the tool positioner

Epoxy dispenser

- Automatic positioning of dispenser needle in 2 direction (Y,Z), based on pneumatic cylinder
- Installed on the tool positioner

Temperature controller

- Heating/Cooling type: thermoelectric cooler
- Temperature control range : 5 ~ 75 deg. celsius (85°C at best efforts)
- Environment temperature : 25 ± 3 deg. celsius

※ Details can be changed for better engineering

Vision Processing

- Automatic angle alignment
- Pattern recognition for probe positioning
- Edge detection and barcode reading

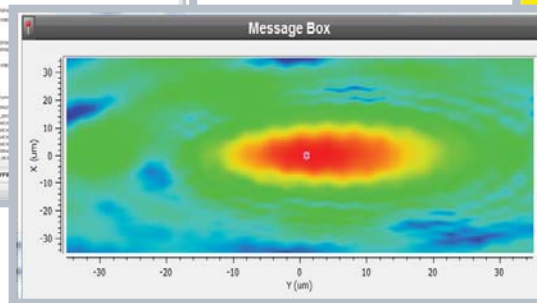
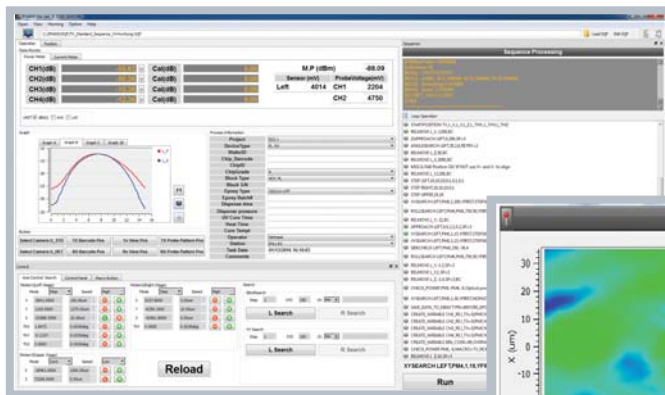
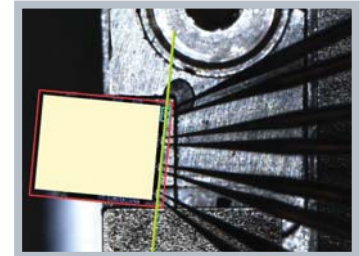
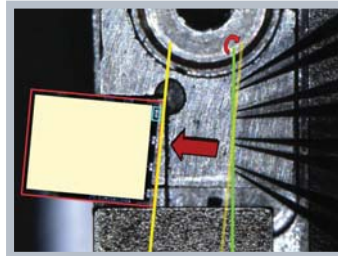

2D scanning

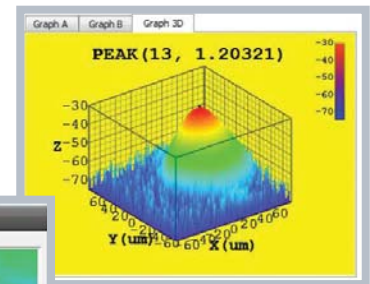

3D scanning

(Automatic alignment or manual pick on power distribution graph)

Graphic User Interface

- Capable of alignment/epoxy bonding of optic device based on vision processing and optic feedback
- User programmable sequence
- Support remote control of client's software via TCP/IP communication

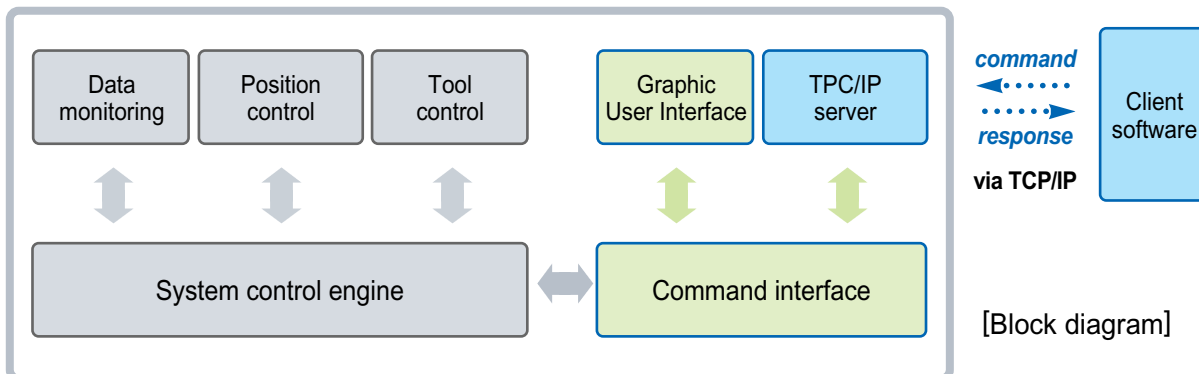

Specifications

Electrical	
Power	110~230 VAC, single phase
Power Consumption	1200 VA max
Pneumatic	
Input Pneumatic Pressure	0.48~1.5MPa (equiv. to 70~210 psi)
Mechanical	
System Dimensions (W x D x H)	1,010mm x 800mm x 1,550mm (measurement instrument and display excluded) 1,300mm x 1,100mm x 1,700mm
Weight	<500kg
Optical Table	Pneumatic vibration isolation table
Alignment mechanism	
Alignment Stage Resolution (In/Output Stage Assembly)	Liner translation stage (X,Y,Z) 0.05um @ 1/20 microstep drive Rotational stage ($\theta X, \theta Y, \theta Z$) 0.0016degree @ 1/20 microstep drive
Supporting Chip Angles	0°, ±8°, ±5° (quick adjustment of angle bracket)
Tool Positioner ¹⁾	0.5um or better @ 1/20 microstep drive
Center Jig	Detachable center jig
Process performance	
Gap Control Repeatability	±1um
Stability Test	0.1dB (peak-to-peak variation for three minutes)
Alignment Repeatability ²⁾	< ±0.03dB typical, ±0.075dB maximum (insertion loss variation)

1) Position control of cameras, UV LED head, epoxy syringe

2) For 11 times of alignment with typical optical splitters

System dimension and space requirements

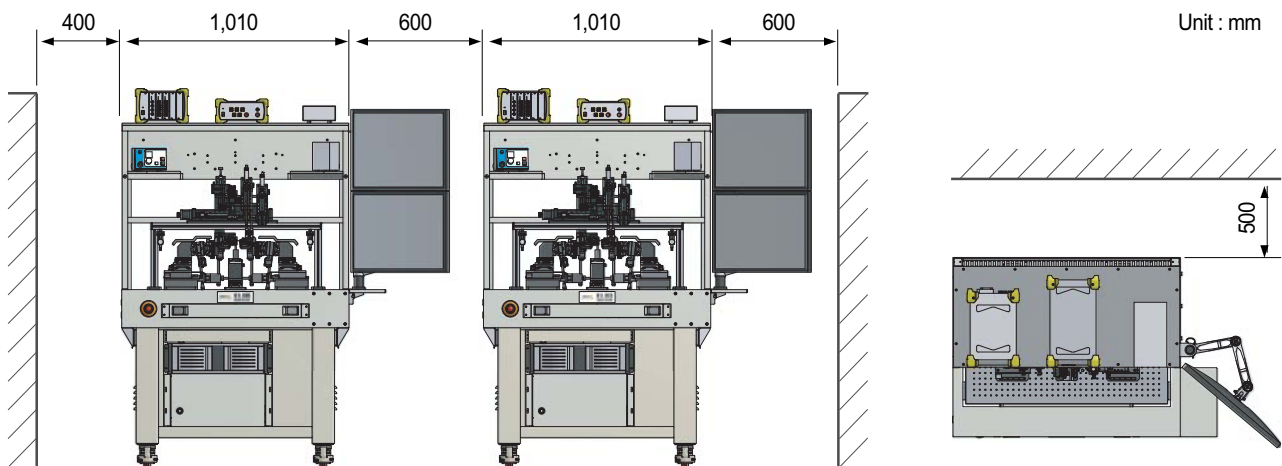



F I B E R P R O

FIBERPRO Headquarters Tel : +82-42-360-0030 Fax : +82-42-360-0050
FIBERPRO USA Tel : +1-408-835-7796 Fax : +1-408-521-0402
FIBERPRO CHINA Tel : +86-27-8663-5497 Fax : +86-27-8663-5701
www.fiberpro.com sales@fiberpro.com

For more information, please visit our web site - www.fiberpro.com - or
email our sales department, sales@fiberpro.com